

PIPE SCREW JOINTS

G EQUAL TEES

G EQUAL TEES

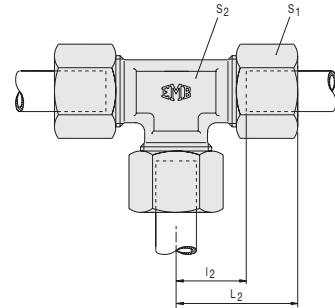

description	pipe OD	PN series	S ₁	S ₂ *	L ₂	l ₂	kg % pc
G 4-LL	4	LL 100 (400)	10	9	21	11.0	2.9
G 6-LL	6	LL 100 (400)	12	12	21	9.5	3.8
G 8-LL	8	LL 100 (400)	14	12/14	23	11.5	5.1
DS-G 6-L	6	L 500 (2200)	14	12	27	12.0	7.1
DS-G 8-L	8	L 500 (2200)	17	14	29	14.0	10.1
DS-G 10-L	10	L 500 (2200)	19	17	30	15.0	13.0
DS-G 12-L	12	L 400 (1700)	22	19	32	17.0	17.7
DS-G 15-L	15	L 400 (1700)	27	19	36	21.0	23.2
DS-G 18-L	18	L 400 (1700)	32	24	40	23.5	35.4
DS-G 22-L	22	L 250 (1100)	36	27	44	27.5	44.3
DS-G 28-L	28	L 250 (1100)	41	36	47	30.5	61.1
DS-G 35-L	35	L 250 (1100)	50	41	56	34.5	90.1
DS-G 42-L	42	L 250 (1100)	60	50	63	40.0	136.8
DS-G 6-S	6	S 800 (3400)	17	14	31	16.0	12.0
DS-G 8-S	8	S 800 (3400)	19	17	32	17.0	15.7
DS-G 10-S	10	S 800 (3400)	22	19	34	17.5	21.2
DS-G 12-S	12	S 630 (2700)	24	22/17	38	21.5	28.5
DS-G 14-S	14	S 630 (2700)	27	19	40	22.0	28.5
DS-G 16-S	16	S 630 (2700)	30	24	43	24.5	35.9
DS-G 20-S	20	S 400 (1700)	36	27	48	26.5	55.8
DS-G 25-S	25	S 400 (1700)	46	36	54	30.0	106.7
DS-G 30-S	30	S 400 (1700)	50	41	62	35.5	134.9
DS-G 38-S	38	S 400 (1700)	60	50	72	41.0	202.2

L₂ = approximate length with nut tightened

OD 4 to 12 mm manufactured from profile material

Please see "Engineering and technical data - Selecting the correct tube fitting" for more information on pressure.

* Depending on type of production, the wrench size may vary in some cases